

## AIRPROX REPORT No 2016023

Date: 12 Feb 2016 Time: 1518Z Position: 5140N 00206W Location: Kemble Aerodrome

### PART A: SUMMARY OF INFORMATION REPORTED TO UKAB

Recorded	Aircraft 1	Aircraft 2
Aircraft	PA28(A)	PA28(B)
Operator	Civ Trg	Civ Trg
Airspace	Kemble ATZ	Kemble ATZ
Class	G	G
Rules	VFR	VFR
Service	Information	Information
Provider	Kemble	Kemble
Altitude/FL	500ft	NK
Transponder	On / S	On / S
<b>Reported</b>		
Colours	Green / White	White / Blue
Lighting	Strobe, Nav, Landing	Anti-Col, Landing
Conditions	VMC	VMC
Visibility	>10km	>10km
Altitude/FL	500ft	600ft
Altimeter	QFE	QFE (977hPa)
Heading	080°	080°
Speed	70kt	70kt
ACAS/TAS	Not fitted	Not fitted
<b>Separation</b>		
Reported	100ft V/0ft H	200ft V/0ft H
Recorded	NK V/<0.1nm H	

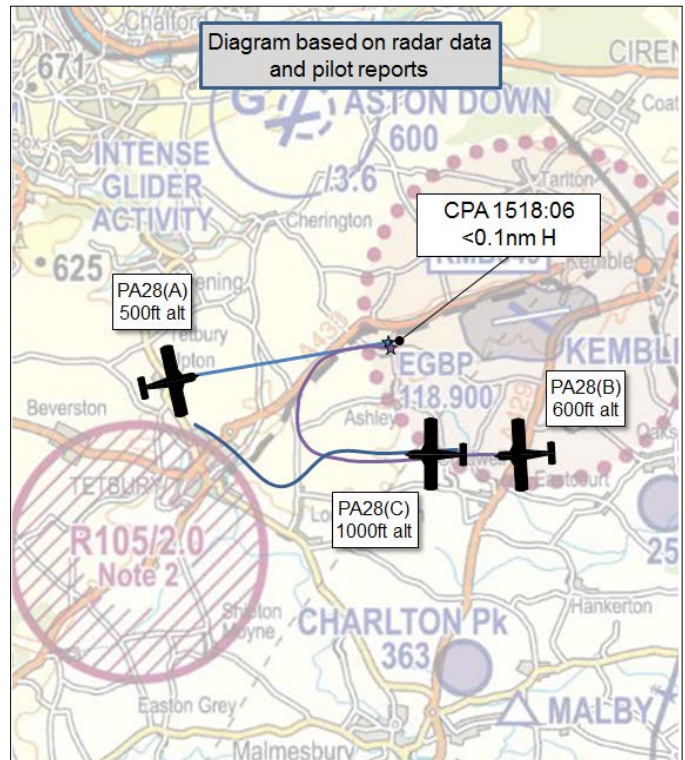

**THE PA28(A) PILOT** reports that Kemble Tower had asked him to extend his final approach. He was approaching Tetbury and advised Kemble Tower he would fly around Tetbury due to the noise abatement and call long final when established. He recalled that the other PA28 (B) did not extend, and turned final above him. Kemble Tower asked both aircraft for their heights, and this established that PA28(B) was higher than him. The first he was aware of the danger was when PA28(B) appeared directly above him.

He assessed the risk of collision as 'High'.

**THE PA28(B) PILOT** reports that after departing and making three orbits of Tetbury, he called Kemble Tower after his last orbit to declare his intention to make an overhead join. This was acknowledged and he was asked to report when overhead. On approaching the airfield another PA28(C) was ahead of him; also making an overhead join. He made his overhead reporting call, keeping aft and a safe distance from the PA28(C). Kemble Tower acknowledged and asked him to report crosswind. He noted that the PA28(C) had taken a very wide dead side track so he reduced speed and maintained an aft position (with landing light on), but with a less wide pattern ensuring that he kept a safe distance from PA28(C). Separation was good, and with PA28(C) ahead of him in the crosswind its pilot made his crosswind call. Kemble tower asked PA28(A) to make an extended downwind leg as a twin-jet was backtracking on the runway to depart. PA28(B) pilot made his crosswind call, and was also asked to make an extended downwind leg. On the downwind leg, PA28(A) made his call for a touch and go; PA28(A) was advised to report final. He followed and made his downwind call and was advised to report final and told there were 2 ahead; he had visual with PA28(C). He continued to monitor PA28(C) on the extended leg, which continued some distance outside of the normal circuit pattern; he then heard a call for long final and it initially looked like PA28(C) was initiating a turn for base and final. However, PA28(C) then appeared to correct his turn and altered his heading towards Tetbury. At this point, assuming PA28(C) had altered his plan

to fly the circuit, he consequently elected to turn onto base after looking out and seeing no other traffic, shortly followed by making a call that he was on long final for touch and go. Kemble tower acknowledged his call and he continued on final track and heard the Tower call "All Stations to confirm their altitude". He was aware that PA28(C) was at this time behind him over Tetbury. However, he heard an unknown aircraft call "on final at 400ft"; he immediately called he was on final at 600ft. The Unknown aircraft then immediately confirmed visual with him as being above and he immediately initiated a climb and called "go around", climbing out over deadside. He then recovered back into the normal circuit pattern and continued with 3 circuits without further incident. At the end of his sortie, he elected to visit Kemble Tower to talk through the conflict situation to try and understand how this situation arose and learn more. It appeared that a shift change had occurred in the tower just after he made his first circuit crosswind call. Equally it appears that one of the two aircraft that was ahead of him was making a long final approach direct into Kemble; he had not positively sighted this aircraft. The learning point he takes from this incident is that he should not have adjusted his position in tracking PA28(C) and his next course of action should have been to abandon the approach and re-plan for another overhead join, coupled with appropriate Air Traffic calls in leaving the circuit and position report.

He assessed the risk of collision as 'Medium'.

**THE PA28(C) PILOT** was interviewed by ATSI via telephone and recalls that he probably made contact with Kemble Information on crossing the M4 motorway, which runs west-to-east and, at its closest point, is 8.5nm south-east of Kemble Aerodrome. He certainly made his call no later than reaching the Kemble Aerodrome overhead. He also recalled the small business-jet departing from Kemble, and that aircraft in the visual circuit were extending downwind to accommodate this; he confirmed that because of this, he also extended his downwind leg. On reaching the town of Tetbury (approximately 4nm south-west of Kemble Aerodrome), the instructor in PA28(C) became concerned of his student's proximity to this built up area and elected to avoid the town by routeing further to the south-west.

**THE KEMBLE FISO** reports that both PA28's had extended downwind due to a back-tracking aircraft on the runway. Both PA28's then made straight-in approaches from about 4 miles he thought, with both reporting final at the same time, in close proximity to each other and not visual with each other. A handover had just taken place in the VCR. The aircraft on the runway had just departed with other light-traffic remaining on the flight progress board. Both aircraft reported Final approach at similar times and were not visual with each other. He believed that both aircraft were about 2 miles final. To aid decision-making, the FISO requested the respective levels of both aircraft; this was identified as 200ft vertical separation, neither aircraft was visual with the other owing to their close proximity. After ascertaining the respective levels of the aircraft, a go around was initiated by PA28(B).

## Factual Background

The weather at Brize Norton was recorded as follows:

METAR EGVN 121450Z 11010KT 9999 SCT025 SCT060 07/07 Q0993 BLU NOSIG

Kemble Aerodrome does not employ accredited meteorological observers; however, the unofficial weather observation for Kemble Aerodrome is reproduced below:

EGBP 121500Z 10009KT 9999 FEW010 BKN030 06/03 Q992  
EGBP QFE 977hPa  
Cotswold Regional Pressure Setting 989hPa

## Analysis and Investigation

### CAA ATSI

ATSI had access to reports from the pilots of PA28(B) and PA28(A) who were operating in the Kemble circuit, the Kemble Aerodrome Flight Information Service Officers (AFISOs), the area radar recordings and the Kemble Aerodrome local Investigation report. In addition, an ATSI Field Investigation was carried out and both AFISOs involved in the Airprox were interviewed at Kemble. Due to a recorder fault at Kemble, the recorded R/T transmissions were unintelligible and therefore unusable. Subsequent to the ATSI Field Investigation, the pilot of PA28(C) was contacted by telephone in order to record his recollection of events. ATSI were able to identify all the individual aircraft involved in this Airprox using SSR Mode S information derived from the area radar recordings. Screenshots produced in the report are provided using the area radar recordings. Levels indicated are altitudes. All times UTC.

At 1509:30 (Figure 1), PA28(B) left the vicinity of Tetbury (4nm west south-west of Kemble) and tracked towards the Kemble Aerodrome overhead with the intention of carrying out an overhead re-join for Runway 08 where a right-hand circuit was in operation.

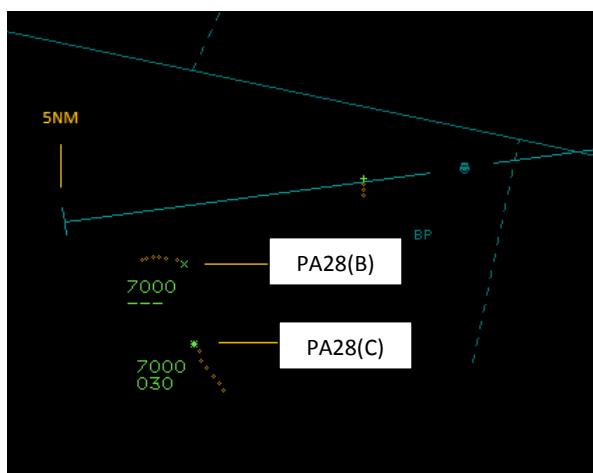

**Figure 1 – Swanwick MRT at 1509:30**

At 1511:45 (Figure 2), PA28(B) was 2nm to the south-west of Kemble Aerodrome and tracking towards the overhead, PA28(A) was mid-downwind right-hand for Runway 08 and a third aircraft PA28(C) was 1.4nm west south-west of Kemble also tracking towards the Kemble overhead. PA28(C) was indicating 2900ft based on the Swanwick MRT QNH datum which was 994hPa. Prior to the Airprox PA28(C) was observed to have tracked towards Kemble from the south-east.

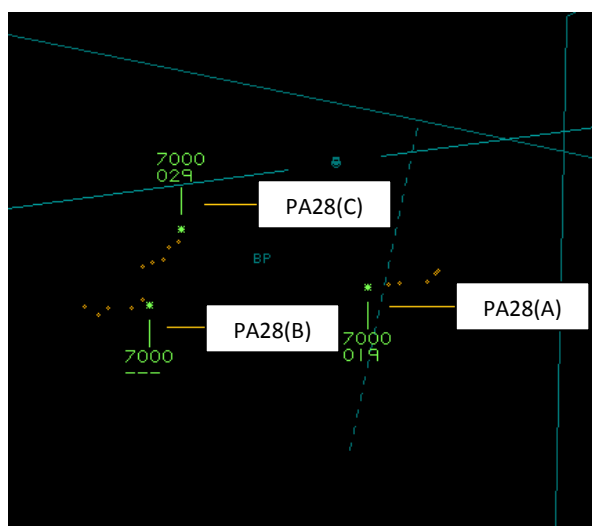

**Figure 2 – Swanwick MRT at 1511:45**

The pilot of PA28(B) did not have Mode C selected, however, at 1513:16 (Figure 3), PA28(B) was observed to be manoeuvring in a manner consistent with having commenced an overhead join. At this time, PA28(B) was 0.8nm astern of PA28(C) who was indicating 2400ft. PA28(A) was late downwind having extended the downwind leg.

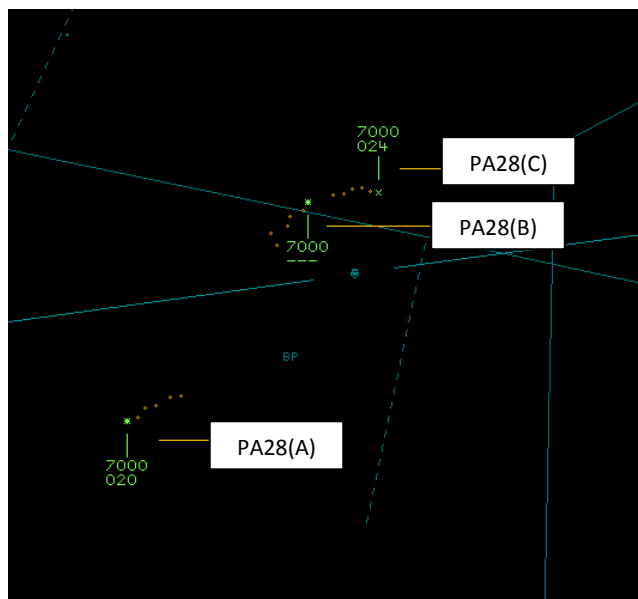

**Figure 3 – Swanwick MRT at 1513:16**

At 1513:50 (Figure 4), PA28(B) was observed to have turned crosswind and was still astern of PA28(C) who was indicating 1900ft. PA28(A) was still late downwind.

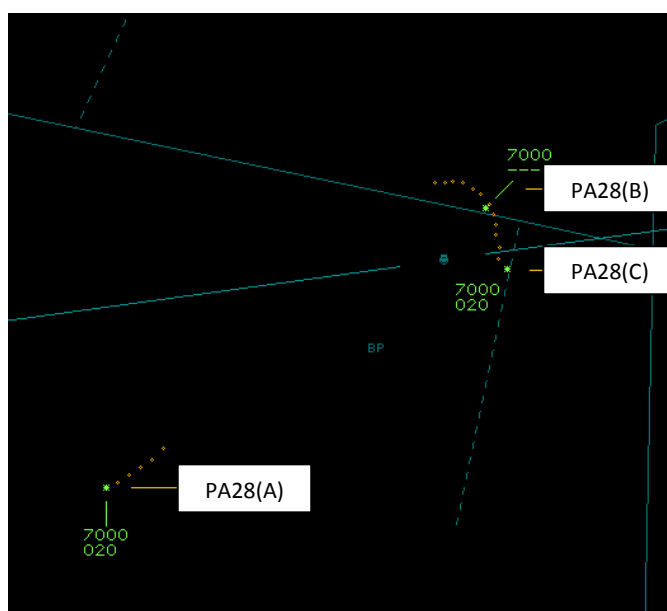

**Figure 4 – Swanwick MRT at 1513:50**

At 1515:45 (Figure 5), PA28(B) was observed to be downwind right-hand for Runway 08. At this time PA28(C) was late downwind right-hand for Runway 08, inside of PA28(B) and indicating 2000ft. PA28(A) was observed about to establish on a long final for Runway 08 at a range of approximately 4nm. Also at this time, a departing aircraft (code 3712) appeared on the area radar recording.

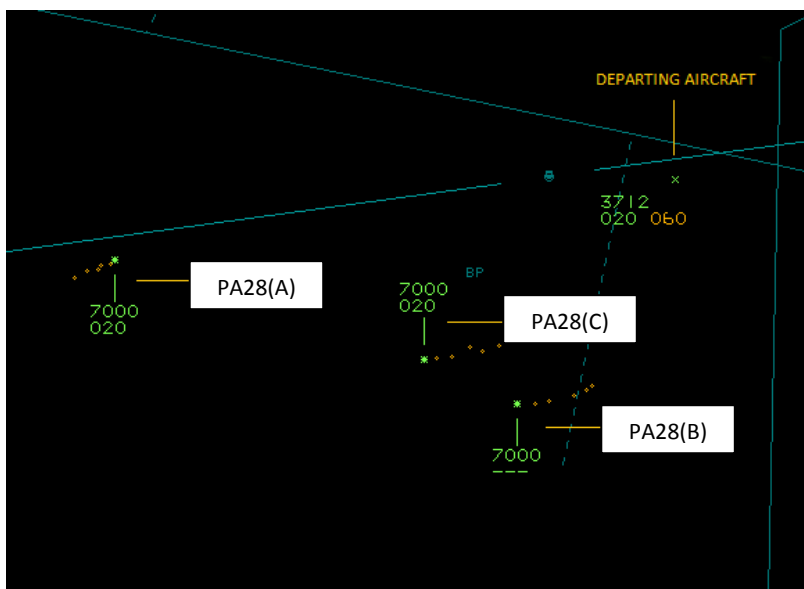

**Figure 5 – Swanwick MRT at 1515:45**

At 1516:47 (Figure 6), PA28(B) was observed to be 2.8nm south-west of Kemble late downwind right-hand for Runway 08 having also extended downwind. PA28(C) was 3.2nm south-west of Kemble and was manoeuvring in a manner consistent with the aircraft having turned right-base. PA28(A) was on final at approximately 3nm.

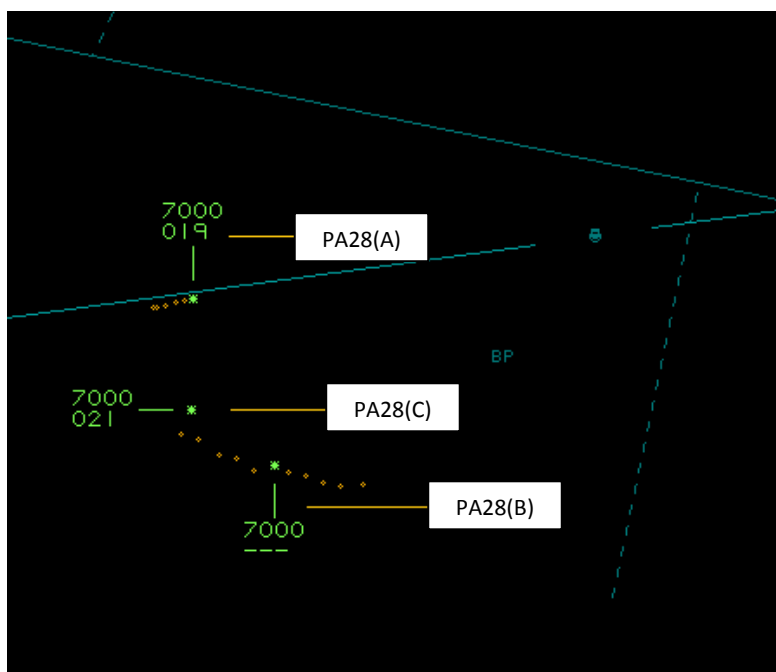

**Figure 6 – Swanwick MRT at 1516:47**

At 1517:04 (Figure 7), PA28(C) was observed to have turned left and tracked to the south indicating 2200ft. PA28(B) was observed to have turned right base. For illustrative purposes, the lateral dimensions of the Kemble ATZ are overlaid in red.

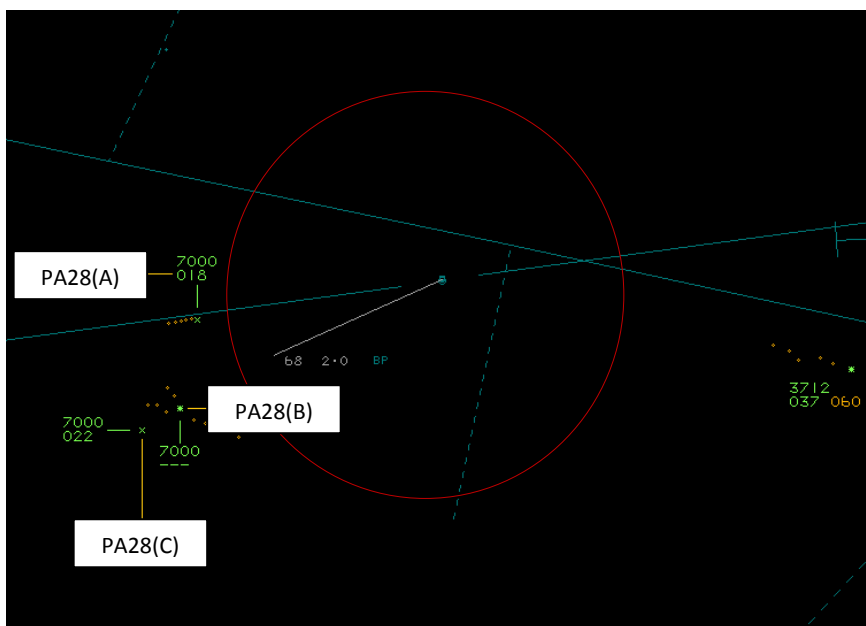

**Figure 7 – Swanwick MRT at 1517:04**

At 1517:25 (Figure 8), PA28(B) was observed on right base and closing the final approach for Runway 08, PA28(A) was ahead on final indicating 1700ft. PA28(C) had tracked away to the south-west.

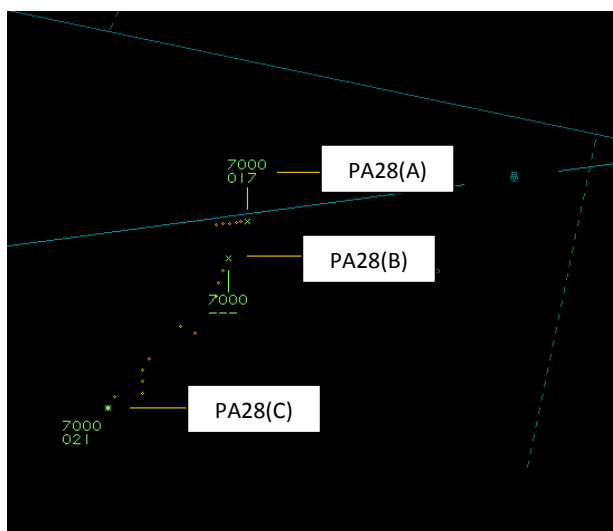

**Figure 8 – Swanwick MRT at 1517:25**

CPA occurred at 1518:23, (Figure 9) with a horizontal distance of less than 0.1nm and PA28(A) indicating 1300ft.

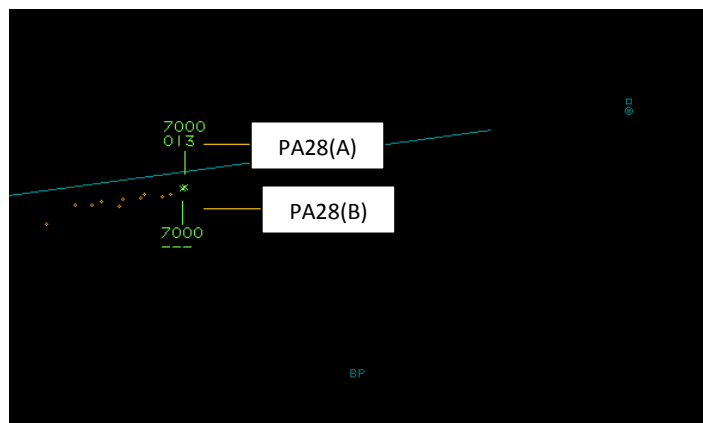

**Figure 9 – Swanwick MRT at 1518:23 (CPA)**

Prior to the Airprox, a change in AFISO occurred. Both the outgoing AFISO and the incoming AFISO were interviewed by ATSI. The outgoing AFISO recalled at interview that a small business jet entered Runway 08 from holding point A3 (Figure 10 with the aircraft's taxi route overlaid in red) and backtracked to the Runway 08 threshold coincident with PA28(A) being crosswind in the circuit. From holding point A3 this involved a backtrack of almost the full length of the runway. As the business jet was backtracking, the outgoing AFISO informed the pilot of PA28(A) of the traffic and the pilot of PA28(A) elected to extend downwind. At interview, both AFISOs were questioned as to whether PA28(A) was instructed to extend downwind and both stated that this was not the case.



Figure 10 – UK AIP AD 2-EGBP-2-1

The outgoing AFISO reported that when PA28(B) reported crosswind, the pilot was given traffic information on PA28(A) and the pilot of PA28(B) advised the AFISO that he would also extend downwind to accommodate the departure. The outgoing AFISO recalled that the reply he gave to PA28(B) was *“one ahead, report final”*. Shortly after this, the outgoing AFISO recalled that he then initiated the watch handover, advised the incoming AFISO that there were two aircraft in the visual circuit, and that they had both extended downwind to accommodate the departing traffic. These details were acknowledged by the incoming AFISO and the watch handover was completed.

At interview, neither the outgoing or incoming AFISO could recollect anything regarding PA28(C), furthermore, due to the recorded R/T data being unintelligible, any information relating to what landing order had been agreed between this aircraft and PA28(B) and PA28(A) could not be ascertained. The recorded surveillance data indicated that, prior to the Airprox, PA28(C) was manoeuvring in a manner consistent with the aircraft making a standard overhead join for Runway 08 right-hand at Kemble. The Mode C information displayed by PA28(C) could not be verified as it is not known which pressure setting was being used.

The incoming AFISO explained that PA28(B) and PA28(A) both reported final at similar times, he observed the two aircraft in proximity and, because they were both of the same aircraft type, was therefore unable to confirm which was which. He then requested that the pilots of PA28(B) and PA28(A) report their respective levels in order to aid both pilot's decision making. After ascertaining this information, the pilot of PA28(B), initiated a missed approach.

Prior to the Airprox, the pilots of PA28s (A), (B) and (C) had elected to extend their respective downwind legs to accommodate the departure of the small business jet. In so doing, PA28s (A) (B) and (C) flew wide circuits, causing them to fly outside the confines of the Kemble ATZ.

The AFISOs were providing an Aerodrome Flight Information Service within Class G (uncontrolled) airspace. AFISOs are not permitted to issue instructions to aircraft in the air<sup>1</sup>, pilots are therefore wholly responsible for collision avoidance in conformity with the Rules of the Air.

<sup>1</sup> CAP797 Chapter 1



## UKAB Secretariat

Both PA28 pilots shared an equal responsibility for collision avoidance and not to operate in such proximity to other aircraft as to create a collision hazard<sup>2</sup>. An aircraft operated on or in the vicinity of an aerodrome shall conform with or avoid the pattern of traffic formed by other aircraft in operation<sup>3</sup>.

### Summary

An Airprox was reported when two PA28's flew into proximity 1.4nm west of Kemble Aerodrome at 1518 on 12<sup>th</sup> February 2016. Both pilots were operating under VFR in VMC, both pilots in receipt of an AFISO Service from Kemble. PA28(A) was operating VFR on a circuit training detail at Kemble Aerodrome and was being flown by a solo student pilot. PA28(B) was operating VFR on a local flight from Kemble Aerodrome; the intention of the pilot was to fly a short, out of circuit flight, followed by three take-offs and landings in order for him to maintain his currency. After reviewing the area radar recordings it also became apparent that a third aircraft (PA28(C)) was a contributory factor in the Airprox. Subsequent enquiries ascertained that PA28(C) was inbound to Kemble on a VFR training flight from Thruxton. This aircraft was also in receipt of an Aerodrome Flight Information Service from Kemble Information.

PA28(A) had extended his circuit as requested, he thought, by the AFISO, and flew out towards Tetbury before establishing on a long final for runway 08.

PA28(C) joined overhead, called crosswind then, when downwind, was also asked, he thought, to extend his downwind leg. He extended to Tetbury as well.

PA28(B) also joined overhead and maintained visual behind PA28(C). PA28(B) extended somewhat downwind but when PA28(C) initially turned right, PA28(B) believed PA28(C) was turning onto base leg. When PA28(C) turned back towards Tetbury, PA28(B) assumed that PA28(C) had decided not to continue in the circuit and so the pilot of PA28(B) turned inside PA28(C) onto base leg and then final. PA28(B) was slightly higher than PA28(A) and approaching at a higher speed, which resulted in PA28(B) catching PA28(A) without being visual. When the Kemble AFISO requested all aircraft to state their height PA28(B) realised he was in conflict with PA28(A) and commenced a go-around.

### **PART B: SUMMARY OF THE BOARD'S DISCUSSIONS**

Information available consisted of reports from the pilots of both aircraft, radar photographs/video recordings and reports from the AFISO's involved and reports from the appropriate ATC and operating authorities.

The Board began their deliberations with a discussion on the service provision provided by AFISO's. Members commented that the PA28 pilots had reported that they had been instructed to extend downwind, whereas it was noted that an AFISO can only issue information to aircraft in their area of responsibility, not instructions. Several members wondered whether less experienced pilots may consider such information as an instruction in the mistaken belief that it had come from a controller. The Board reiterated that the aircraft pilot is responsible for conforming to the pattern of traffic at an aerodrome, and an AFISO does not issue instructions to aircraft in the air. Members believed that it was this misunderstanding of responsibilities that may have resulted in the pilots feeling obliged to carry out their greatly extended downwind legs that had effectively meant that their aircraft had left the visual circuit. Whilst the Board did not believe that this was the cause of the Airprox, they were sure it had been a contributory factor in that the PA28(B) pilot had probably lost situational awareness of PA28(A) as a result. Although it was recognised that a degree of flexibility in circuit ground track was required in order to integrate effectively, members commented that this incident was a salutary reminder of the dangers of extending the circuit pattern to the extremes rather than making an early

<sup>2</sup> SERA.3205 Proximity.

<sup>3</sup> SERA.3225 Operation on and in the Vicinity of an Aerodrome.



decision to either go-around and maintain a predictable ground track, or break off out of the circuit and reposition via an appropriate rejoin. Conducting very long circuit tracks as seen here inevitably ended up affecting other aircraft in the circuit who either had to follow suit or, as in this case, might lose track of where aircraft were if they either missed, or did not assimilate, radio calls. The Board hoped that the forthcoming CAA 'Skyway Code' would help to alleviate both any misunderstanding of the various responsibilities of pilots and AFISOs, and highlight the point at which an aircraft is deemed to have left the visual circuit.

Given the differing reports from the pilots and the AFISOs as to what information was given to the pilots regarding their positioning downwind in the visual circuit, the Board were disappointed that there was no R/T recording available to clarify the situation. Notwithstanding, the Board felt that the AFISO's actions in highlighting that the two aircraft were too close on final approach was a major factor in resolving the conflict and preventing a collision. The Board commended the AFISO for his prompt action.

The Board then turned to the cause of the Airprox. They noted that the PA28(B) pilot had reported that he had been given Traffic Information on '2 ahead', and that he had turned onto base leg as he believed PA28(C) was leaving the circuit. Although there were mitigating factors due to the extremely large circuit flown by PA28(A)'s pilot, the Board felt that PA28(B)'s pilot had either simply not assimilated the Traffic Information that there was another aircraft ahead of him in addition to PA28(C), or had possibly thought that PA28(A) had probably already completed his circuit. Whichever, it was clear that PA28(B) was not visual at any time with PA28(A), and was only alerted to its presence by the PA28(A) pilot's call of his height and position. The Board determined therefore that PA28(B) pilot had not sequenced effectively with PA28(A). Turning to the degree of risk, the Board had a hearty discussion as to whether the risk was Category A or B (providence vs avoiding action). Eventually, the majority decision was that the AFISO's call had prompted PA28(B) pilot to go around, and that this constituted avoiding action. Nevertheless, it was agreed that safety margins had been much reduced below the norm.

### **PART C: ASSESSMENT OF CAUSE AND RISK**

Cause: The pilot of PA28(B) did not sequence with PA28(A).

Contributory Factor(s): The PA28 pilots flew an extended downwind, outside the bounds of the promulgated Kemble visual circuit.

Degree of Risk: B.